

COMPACTFLAT S15

PROJECT REPORT

Roof_1

02/11/2020



CONTENTS

Introduction	3- 4
Project Data	5- 5
Project Location Google Maps	6- 6
Roof data	7- 7
PV-Module	8- 8
Racking Parameter	9- 9
Position	10-10
Disposition - Google Maps	11-11
Installation-Plan	12-12
Static CAD	13-13
Elevation Parameter Additional Info	14-14
Resulting surface stresses	15-16
Additional Information	17-17

INTRODUCTION:

Thank you for choosing the Aerocompact mounting system.

Please read these instructions carefully before starting the installation and make sure that you can meet the required guidelines in this installation manual.

An important part of this Project Report is the installation manual, please read and follow this manual step by step. Please make sure that the position of the modules on the roof and the ballast distribution is installed as required in project report. In case the module layout changes do to circumstances like obstructions, the ballast calculation needs to be modified with the Aerotool software. It is required to design the static calculation of the system with the Aero Tool Software program (Solar.Pro.Tool).

The technical documentation is part of the product. The company AEROCOMPACT is not liable for damages occurring from non-compliance with the installation instructions, particularly the safety instructions, as well as from misuse of the products. In addition to this installation manual the current general conditions as well as warranty conditions apply. The current versions are available at www.aerocompact.com

Faults and damage as well as limited or lacking operability of the system as a result of assembly that is faulty and/or deviating from the installation instructions and/or the project report (Solar.Pro.Tool) preclude a material defect is not the responsibility of Aerocompact. With unprofessional installation, all rights of the purchaser shall expire. The required compressive strength of the roof insulation and the maximum static roof load needs to be checked before starting the installation.

Photovoltaic flat roof systems are not maintenance free. Maintenance, particular the right position of the ballast blocks and the building protection pads should be conducted annually. For exceptional high-wind events, we recommend to do a Maintenance and system check right after the storm event.

Faults and damage as well as limited or lacking operability of the system as a result of assembly that is faulty and/or deviating from the installation instructions and/or the project report (Solar.Pro.Tool) preclude a material defect is not the responsibility of Aerocompact. With unprofessional installation, all rights of the purchaser shall expire. The system warranty shall be effective only if all system components were purchased from Aerocompact.

The system requires that the module can also be used with this type of assembly (clamping to the short sides of the module). This release can be present either generally within the scope of module certification or may in some circumstances also be provided project-specifically by the module manufacturer.

The aluminum coating of the building protection mat that is included in the scope of delivery prevents any leaking of plasticizers. Because of the variety of different sealing types previously and currently customary on the market, compatibility and the minimum required friction coefficients between the protective building mat and the roof structure of the building must be ensured by the assembly company / buyer. A (wet) friction coefficient of at least 0.7 for TPO roofs and 0.4 for Bitumen roofs must be adhered to in order to ensure system stability.

If the Roof-Gravel is located right on the water-bearing roof the Aerocompact System can not be installed on the gravel layer. The gravel must be removed in this case in the area of the Aluminum Brackets.

In case of doubt, please contact the Team of Aerocompact directly at office@aerocompact.com or call 0800 578 0474

ASSEMBLY COMPACTFLAT S15

25° tight (US: available)

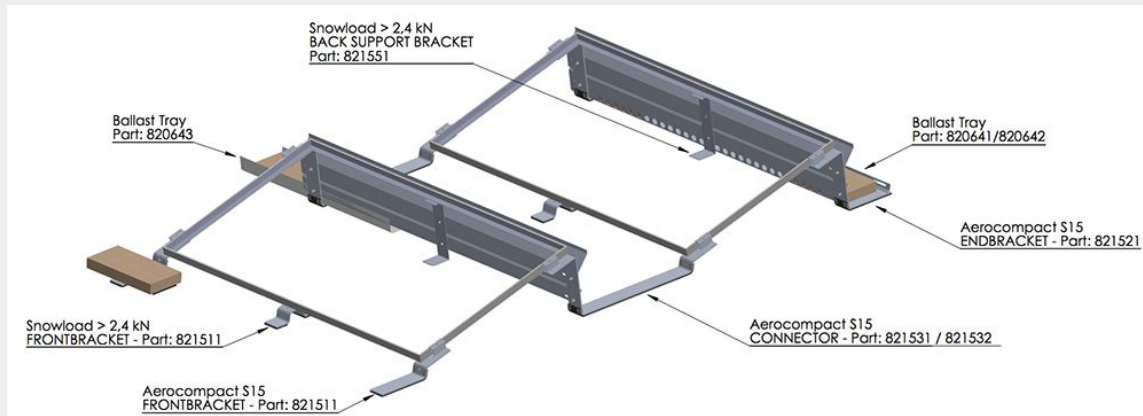

ARRAY ASSEMBLY

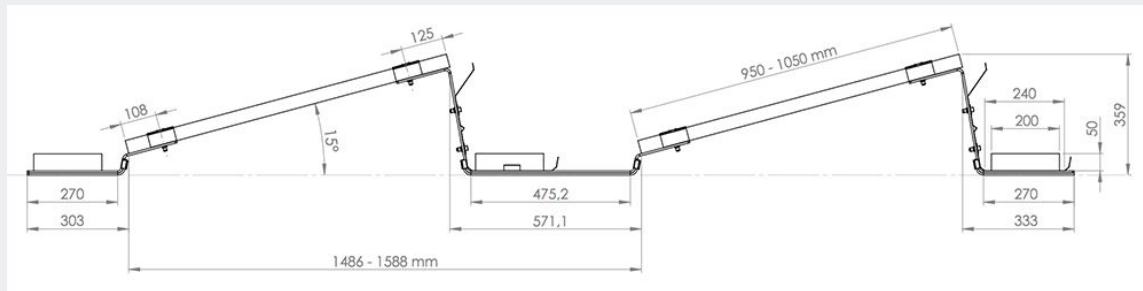
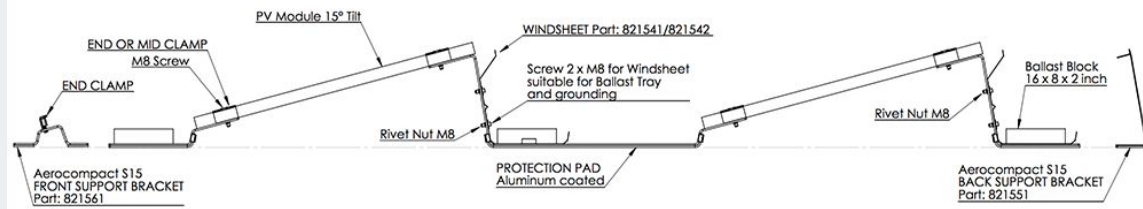

MASTER DATA

Project Name	<input type="text"/>
Project Number:	ae_DE_asqC8VMe
Comment	Nordichand
Planning Responsible	Mati Rändva
Amount Modules	111
System Size	36.08 kWp
Orientation [°]	214
Roofpitch [°]	1

PROJECT ADDRESS

Name	<input type="text"/>
Street Address	<input type="text"/>
Postal code	<input type="text"/>
City	Loo
Phone	
Email	
Notes	
Country	Estonia
Latitude °	<input type="text"/>
Longitude °	<input type="text"/>
Altitude [m]	39



PROJECT LOCATION

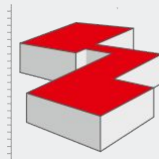
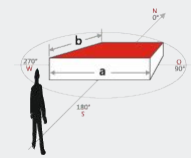

ROOF [ROOF_1]

Building height h [mm]	15000	<p>Custom(Elev.)</p>  <p>System alignment [°]*</p> 
Slope of roof [°]	1	
Roofing	Bitumen Roof	
Product Type:	COMPACTFLAT S15	
System alignment [°]	214	
Parapet height [mm]:	200	
Parapet width [mm]:	100	

To counteract the sinking of brackets into the bituminous roofing layer softened by heat in summer, it is recommended to underlay each bracket with a piece of bituminous roofing sheet over its entire surface

SNOW LOAD

Snow load [kN/m²]* (si=μi*sk) (PV modules)	1.5
Slope of roof [°]:	1
Snow load zone	Area 2
Shape coefficient μi:	0.8
Reduction over useful life: (nach EN 1991-1-3, Anhang D)	1
Reduction over reliability class: (nach EN 1990, Anhang D, Tab. B.1,2,3)	1

WIND LOAD

Wind load [kN/m²]	0.4
Building height h [mm]*	15000
Exposure Category	4
Reduction over useful life: (EN 1991-1-4, Abschnitt 4.2)	1
Reduction over reliability class: (nach EN 1990, Anhang D, Tab. B.1,2,3)	1



PV-MODULE [ROOF_1]

Manufacturer:	JA Solar PV Technology Co. Ltd.
Name	JA Solar Mono JAM60S09-325/PR
Width [mm]:	996
Height [mm]:	1657
Thickness [mm]:	35
Framing:	Aluminium
Weight (kg)	18.4
Nominal Power [Watt]:	325
Module Type:	Monocrystalline
Installation:	On Both Sides
Frame color	Aluminium
Temperature coefficient [%/°C]:	-0.37
Efficiency STC:	0.197
Output current MPP - STC [A]:	9.72
Output voltage MPP - STC [V]:	33.44
Short circuit current [A]:	10.25
Open circuit voltage [V]:	41.04
Temperature coefficient Current [%/K]:	0.06
Temperature coefficient Voltage [%/K]:	-0.3
Max. System voltage EU:	1000
Max module backcurrent [A]	20
Galvanic separation required:	No

RACKING PARAMETER [ROOF_1]

Bracket tilt α [°]:	15
Inter-row spacing a [mm]:	571
Maximum height of rack incl. Module [mm]:	359
Friction Constant μ	0.5
<p>Suggested friction constants need to be checked by the installer/customer (wet and dry testing). In case the onsite testing results in a lower friction constant, the latter must be entered here for the static load calculation. Friction constants suggested for flat roofs are based on tests on typical roofing foils carried out by Aerocompact in cooperation with TÜV Rheinland. Friction constants suggested for other surfaces are based on tests carried out by Aerocompact in addition to the former. Similar surfaces made up of comparable materials may show diverging friction constants.</p>	
Stone weight [kg]	8 kg
Height H [mm]:	60 mm
Length B [mm]:	300 mm
Width T [mm]:	200 mm
Distance to roof edge [mm]:	1200

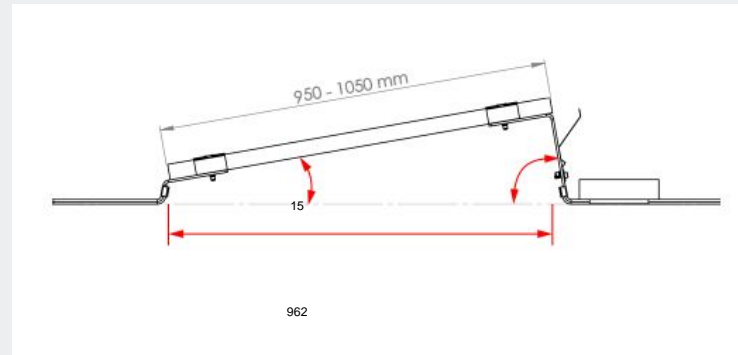

POSITION [ROOF_1]

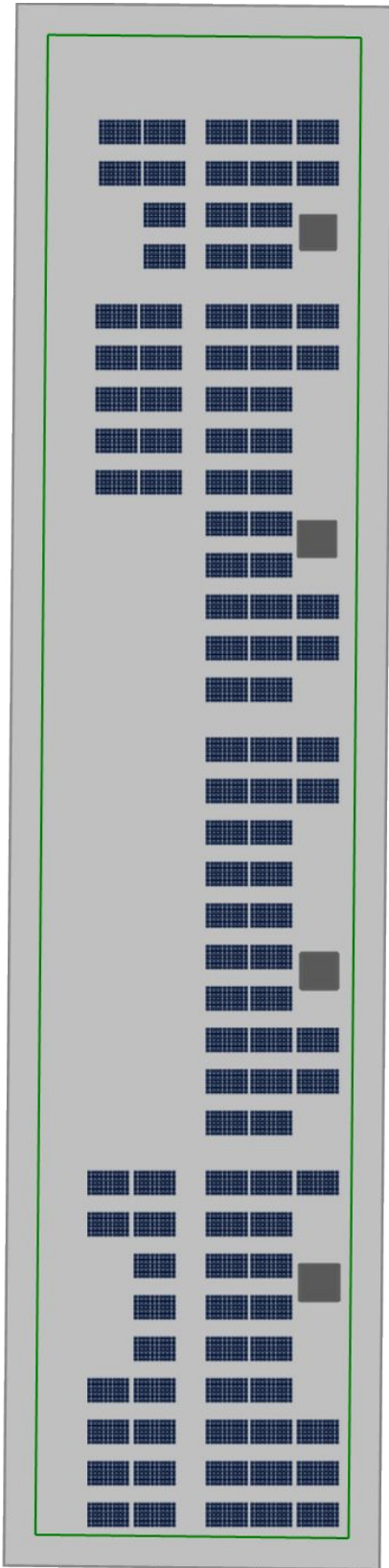

DISPOSITION - GOOGLE MAPS [ROOF_1]

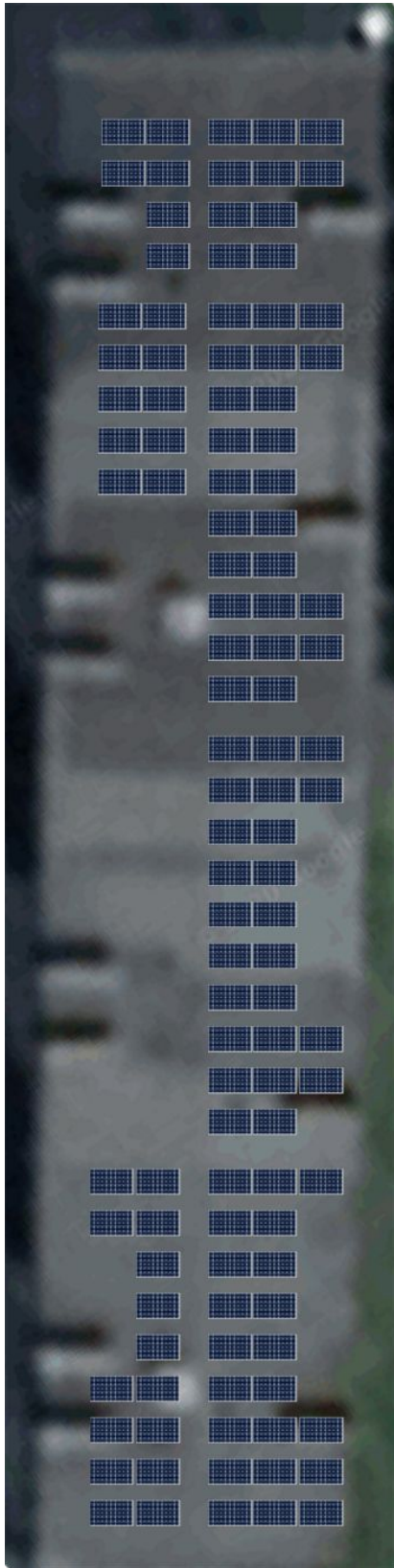

INSTALLATION-PLAN [ROOF_1]

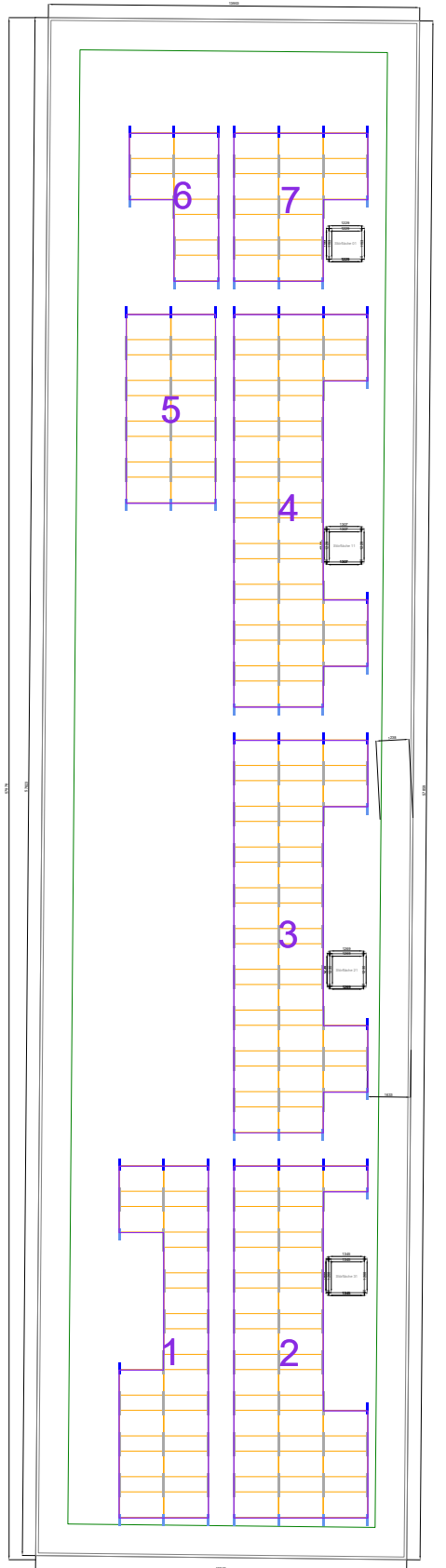

- Alpine Snowload Bracket
- Back
- Connector
- Front
- PV Module

STATIC INFORMATION: BALLASTING [ROOF_1]

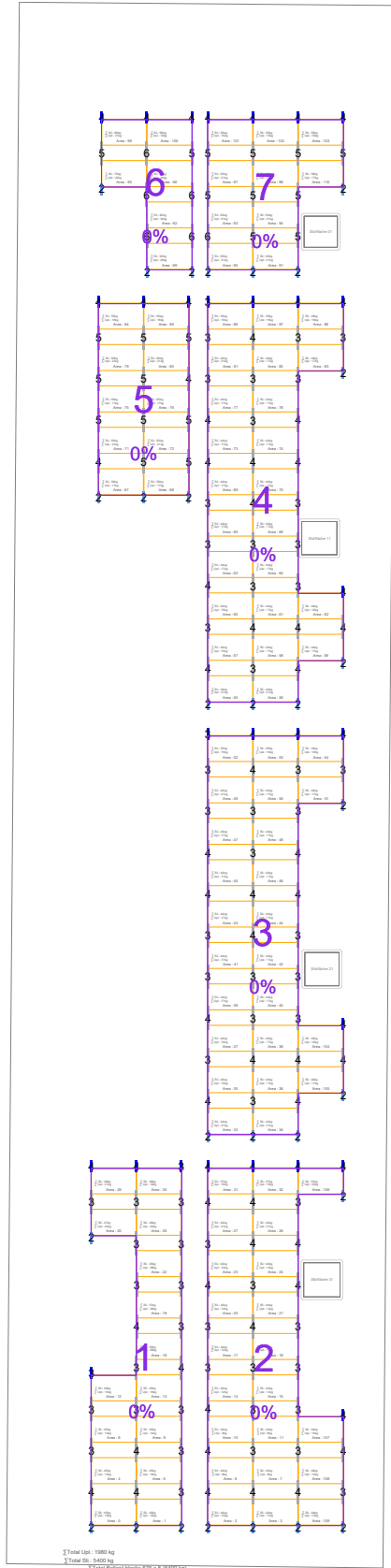

STATIC - IMPORTANT PARAMETERS AND OUTPUT VALUES [ROOF_1]

The average load of the system based on the whole roof surface (incl. Module, mounting system and ballasting) is: [kg/m ²]	9.84
--	-------------

The average surface load of the combined arrays in the system (incl modules, racking system, inter-row spacing and ballasting) is:	23.92 kg/m²
--	-------------------------------

Factor of Safety for Uplift	1.5
-----------------------------	------------

Factor of Safety for Sliding	1.5
------------------------------	------------

Load factor applied to Dead Load	0.9
----------------------------------	------------

Weight per ballast block [kg]	8
-------------------------------	----------

Number of ballast blocks:	675
---------------------------	------------

System surface area [m ²]	332
---------------------------------------	------------

Total ballast weight [kg]	5400
---------------------------	-------------

Weight Module/Rack [kg]	2540
-------------------------	-------------

Total System weight [kg]	7940
--------------------------	-------------

The structural analysis is based on wind tunnel report of the I.F.I. Institute of Industrial Aerodynamics GmbH, No. SSS03 issued 07.09.2015.

BALLASTING

Laydown all required ballast blocks according to the static calculation of the project report on the front, connector and end bracket. Place the protection pads always on the right and left side underneath the blocks and ballast trays. We recommend 2 mats per ballast block or ballast tray. For the long ballast tray 4 piece mats are provided.

The used ballast blocks must comply with the local weather conditions and have to have a compressive strength of min. 21 N / mm² or 3000 psi.

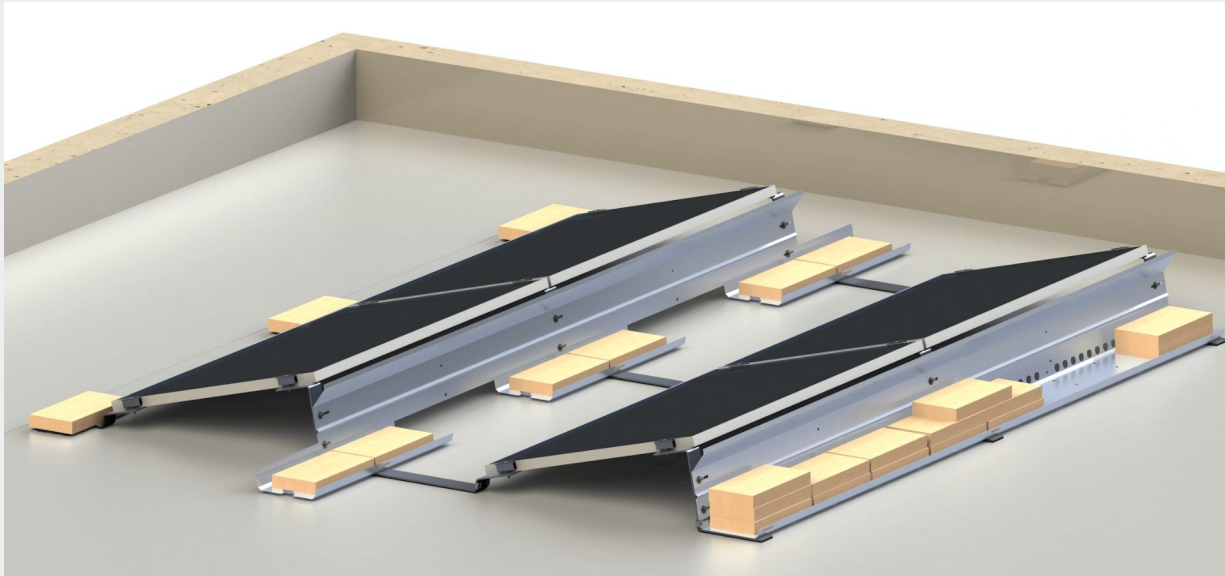

Option A: Standard ballast without tray, ballast is placed directly on the bracket.

Option B: Ballast tray up to max. 8 blocks.

Option C: Long ballast tray up to max. 16 blocks.

WARNING: Don't leave the construction side before the modules are tightened and all the required ballast blocks are placed according to the project report. Without installation of the ballast blocks the stability of the module array is not guaranteed. The correct position of the ballast blocks and building protection pads must be checked at the annual maintenance inspection. It is the responsibility of the installer to check the required ballast block specification and weight.

GROUNDING

Upon completion of the installation, all metal parts of the system need to be integrated into potential equation and, according to relevant electrical codes, grounded. Module frames may be exempt from this obligation (usually not in the USA), as PV modules tested / certified / listed by IEC and/or UL have a proof of electrical isolation. As the Aerocompact module clamps with grounding pins establish a safe electrical connection between module frame and mounting system, potential equation within a module array is provided automatically. For connection between arrays and to a grounding system, as a rule one grounding clamp per module array is sufficient. Watch local legislation / jurisdiction!

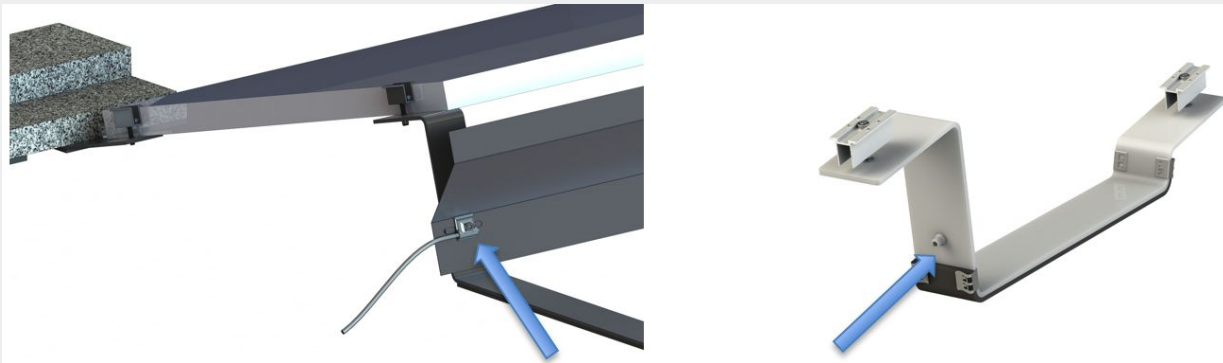

Depending on the type of clamp used, the connection to potential equation and grounding may be, for example, integrated into the fixation of ballast trays or wind sheets to Aerocompact brackets.

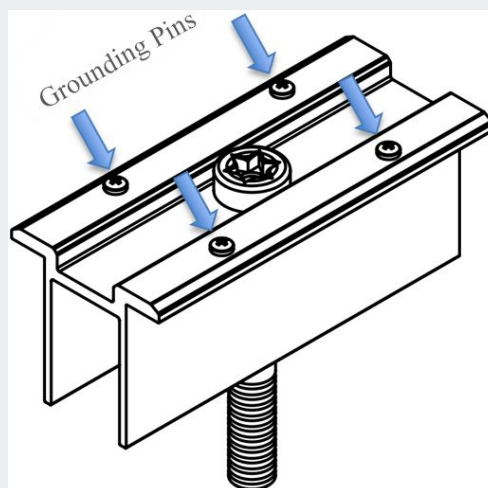

The grounding pins of the module clamps pierce the isolating anodization coating of the module frame, and thus establish electrical connection to the other system components. Tested and certified according to UL 2703.

"ATTENTION: Make sure that the PV system does not interfere with the building's lightning protection (external and internal protection). In ideal circumstances, the PV system is installed within the range of the external lightning protection and keeps the required separating distance from the components from the lightning protection system. If not, seek advice from specialized engineer or company.
ATTENTION: Aerocompact takes no liability for damages related to potential equation, grounding, and lightning protection. "

DISCLAIMER/OTHER LIABILITY

1. This current order specifies expressly no review of any information provided by Principal. Any pertinent review must be ordered expressly and separately in writing.
2. The current report is based on the documents or information and data received by Principal.
3. Therefore, this report can only be as good as the quality of the information of the Principal permits.
4. For these reasons, no liability whatsoever and no warranty for errors based on untrue information of the Principal can be assumed despite any applied due diligence. However, any liability toward third parties is excluded.
5. Contractor (Aerocompact) shall be liable toward Principal only in cases of gross negligence (intent or gross negligence) except for personal injuries. This applies equally to damages to third parties engaged by Contractor.
6. Principal is only entitled to file a claim for damages within six months from the date the damaged party gained knowledge of the damage but no later than within two years following the incident on which the claim is based.
7. Principal has the burden of proof, i.e. Principal must show that the damage is caused by Principal.
8. The structural calculation of the building components refers only to these components.
9. The Supplier is not responsible for the project-related structural soundness of the roof structure and the professional realization and installation.
10. The technical specifications are an integral part of the product. AEROCOMPACT® shall not be liable for damages caused by non-compliance with the installation instructions and particularly with the safety information and from the improper use of the products. The current Terms and Conditions, Warranty Terms and Conditions and Installation Instructions will be provided on www.aerocompact.com.
11. If the roof gravel is located directly on top of the water-bearing roof membrane, Aerocompact® cannot be placed on the gravel layer. In this case the gravel must be removed in the area of the Aerocompact® bracket.
12. The required compressive strength of the roof insulation needs to be examined. An approval from the roof-membrane manufacturer is required.
13. Photovoltaic flat roof systems are not maintenance free. Maintenance, particular the right position of the ballast blocks and the building protection pads should be conducted annually. For exceptional high-wind events, we recommend to do a Maintenance right after the storm event.
14. Place of jurisdiction, Feldkirch Austria